

Cable-type displacement converter

SWM series

for use with absolute and incremental encoders



- **Very robust construction for mechanical engineering and industrial plant application**
- **For converting linear displacements of up to 5 m into a rotary movement**
- **For mounting onto an absolute or incremental encoder**
- **Easy to install and to use**
- **Protection grade IP 65 (IP 54)**

Functional description

The linear movement of a flexible steel cable, which can have a length of up to 5 m, is converted into a rotary movement with the aid of a measuring drum. The measuring drum is connected to the shaft of an encoder. In this way a change in displacement of the measuring cable causes the shaft of the encoder to rotate by a directly proportional amount which can be recorded.

The restoring force of the spring drive holds the measuring cable tight at all times and prevents any sagging which would otherwise induce an error. The cable is wound up precisely and reproducibly wrap for wrap in the helical groove of the drum.

The nozzle, through which the cable enters the drum, is protected with a brush and a bellow to prevent water or dust entering the drum. Two roller units at the cable entry allow for up to 20° deflection of the cable.

Form of delivery

Generally encoders and converters are supplied as one unit. Upon request both items are also available as separate units.

To load the encoder model series KR, CR and TM are suitable with digital interface, DAF and TM with analog interface and pulse of the series, GIO and GIM TB. Preferably used are those with the flange-58th.

Technische Daten

- Measuring ranges: 1 / 2 / 3 / 5 m
- Drum circumference:
 Measuring range to 3 m 200 mm nom.¹⁾
 Measuring range to 5 m 332 mm nom.¹⁾
- SPermissible cable speed: 4 m/s
- EForce required to draw
 out the cable (start / end): 15 N max. / 30 N max.
- Cable material: Edelstahl 1,4401
- Cable diameters: 0,55 mm (nom.)
- Lifespan: $\geq 5 \times 10^6$ cable strokes
- Fleet angle: 20° in all directions
- Housing material: anodized aluminium
- Spring housing: plastic
- Protection grades: Housing IP 64
 Cable entry IP 54

- Working and storage
 temperature range: -20 °C to +70 °C
 -30 °C (option)

- Mass: 1.0 / 1.0 / 1.5 / 2.0 kg

Order code format

SWM	5	B	01	
			01	Basic version for model No. 58*
				Accessories:
		B		with bellows (standard)
				Measuring ranges:
	1			1 m
	2			2 m
	3			3 m
	5			5 m
				Model:
SWM				Cable-type displacement converter

* Variations from the basic version are indicated with a succeeding, additional number and are documented in our works.

Installation drawings

Dimensions in mm

Cable-type displacement converter SWM
measuring ranges 1 m, 2 m and 3 m

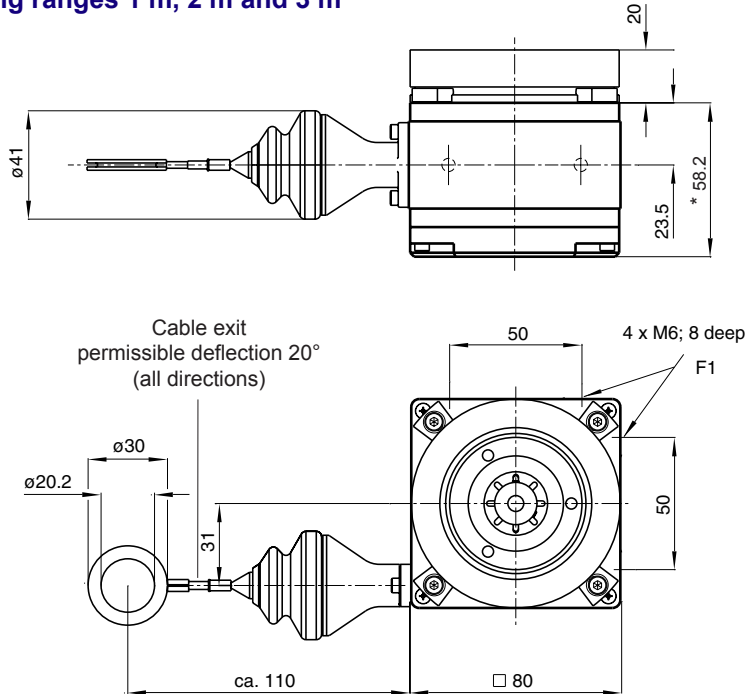

* SWM 3m 79.9 mm.

Mounting position

The F1 threaded holes at two faces permit to adjust the position of the cable exit to suit the requirements in situ.

It is recommended to lay the cable exit vertically downwards or sideways.

Cable-type displacement converter SWM
measuring range 5 m

