



LS 1500 F

User Manual



**ADVANCED SYSTEMS
FOR AUTOMATION & DIAGNOSTIC**

FAE S.r.l. - VIA TERTULLIANO, 41 - 20137 MILANO
TEL. ++39-2-55187133 (ric. aut.) - FAX ++39-2-55187399

Table of Contents

1. General
2. Safety Instructions
3. Operating Conditions
4. Components and Accessories
5. Setup and Functioning
6. Connection to Cable Port
7. User Selections
8. Adjustable Parameters
9. Starting Up
10. Distance Measurement
11. Speed Measurement
12. Operating Range
13. Performance Specifications
14. Service, Maintenance, Warranty
15. EG Conformity Declaration

1. General

The Laser Distance Measurement Module LS 1500 F is designed to allow mobile and stationary hand-held **measurement of distances or monitoring of road traffic for travel speeds,**

Essential features are:

- Field operation under extreme temperatures with high accuracy and large working range.
- Broad range of operating voltages (10 V= to 30 V=) supplied from an on-board electrical system of motor vehicles, an industry-standard DC voltage net or a DC voltage power pack.
- Low, stable power consumption (less than 5 W),

Extension of working range to more than 1500 m for distance and speed measurement applications through additional reflectors mounted on target object.

- Simple aiming at targets at close range over notch and bead sighting device, To sight targets located at larger distances, a light point sight is provided,
- Collective, flexible, extendable interface cable for supply voltage, bidirectional data interfacing, switching output and analog output,
- Commands for measurement functions and output of measured values can be entered at the PC or a laptop.
- Switching output and analog output can be programmed separately with different parameters,
- Averaging of individual distance readings and plausibility statements with selectable distance measurement times,
- Positive or negative excession of distance is signalled via switching output (with selectable distance barrier),
- Readoff options in metres, feet, inches, and other units of measure made more convenient by randomly selectable scaling.
- Class 1 laser according to EN 60825-1',1997-03, absolutely eyesafe, versatile in use,
- Automatically detects presence of optical jamming emitters or optical distance sensors along the measurement path.
- Measurement can be triggered in synchronised mode from external trigger device.

2. Safety Instructions

Safety and operating instructions must be read carefully and followed in practical usage!

The specified conditions must be observed when operating the LS 1500 F.

Non-compliance of these instructions or improper usage may physically injure the user, or damage the rangefinder module.

In the event of necessary repair, the LS 1500 F may be opened by noone other than duly instructed service personnel. This is necessary to prevent exposure to dangerous laser radiation or electrical voltages.

To operate the LS 1500 F, use only DC supply at voltage levels between 10 V and 30 V.

Do not operate the module, when its optical components are dimmed or contaminated.

Do not touch any optical surfaces of the module with bare hands.
Use caution when you remove dust or dirt from these parts.

Protect the module from mechanical shocks during operation and transportation.

Prevent overheating of the module as a result of lasting direct insolation, This applies also when storing the module in a motor vehicle.

3. Operating Conditions

The Laser Distance Measurement Module LS 1500 F is designed for mobile and stationary hand-held distance measurement or speed enforcement performed under field conditions.

Range of operating temperatures -20°C to +60°C

Range of storage temperatures -40°C to +70°C

The rangefinder is splash-proof and built to comply with internal protection standards IP 65.

Two threaded holes are provided in the base plate for mounting the module at the operation site.

The Laser Distance Measurement Module LS 1500 F qualifies for laser class 1 under EN 60825: 1997-03, It emits laser radiation which is not harmful to the human eye, No safety precautions or protective measures are required for normal operation,

Laser Class 1

4. Components and Accessories

Delivery of the LS 1500 F includes an interface cable (2 m in length) and a user manual.

Shipment is in a stable padded cardboard box which can also be used for safer transportation of the module,

The following accessory parts are available on request:

- one reserve interface cable of 2 m length,
- one light point sight,
- one plastic reflector (cat's-eye 84 mm in diameter with central hole for mechanical attachment).

Optionally, an extended interface cable may be provided. It allows for a larger distance between rangefinder position and position of PC and electrical supply if required to match local conditions. Please contact us for a customised solution to your specific requirements!

To increase the distance range in distance measurement applications over 100 m and beyond, one or preferentially more plastic reflectors should be affixed on a white sighting screen of 0,5m x 0.5m, which can easily be seen from a large distance, For jobs, where distances beyond 1000 m need to be measured frequently, we are able to provide an easily visible target screen covered with reflective sheeting.

The light point sight (part of accessories package) is intended for precise aiming at targets to be measured under laylight or twilight conditions.

Performance specifications of light point sight:

Temperature range	-10to+500°C
Effective magnification (X)	1
Effective size of sighting point at 10 m distance	6mm
Diameter of exit pupil	11 mm
Physical dimensions	96x45x35
Mechanical attachment	dovetail way
Lifetime of one set of batteries	50 hours
Weight	155g

5. Setup and Functioning

The LS 1500 F measures the time of flight which invisible laser pulses take to travel to a sighted target and back. Subject to measurement is the diffuse or regular back-scatter signal of the laser pulse, which the rangefinder receives from the target surface.

A microcomputer is built into the LS 1500 F to fire a diode laser at periodic intervals. Within a selectable measurement time, a series of extremely short infra-red light pulses is emitted. These are focused by the transmitter optics to emerge as a laser beam. The signal pulses reflected back from the target are picked up by the receiver optics and directed onto a photodiode which delivers electrical reception signals of a suitable shape. An evaluation unit determines the time from the emission of a pulse to the reception of the corresponding return pulse. This is used as a measure of the target distance.

The microcomputer stores and re-processes the individual measured values.

The speed of a target can be determined from the amount of change occurring in the distance to this target during a given time of measurement. This is done by compiling a regression line chart from all individual measurement points for mathematical calculation of the speed. The sequence of distances is then analysed for its plausibility under various acceptance criteria.

If an acceptance criterion is not met, an error message will be displayed instead of the speed reading. For each target which can be spotted within the given distance range, the initial distance reading is displayed independently

View of LS 1500 F

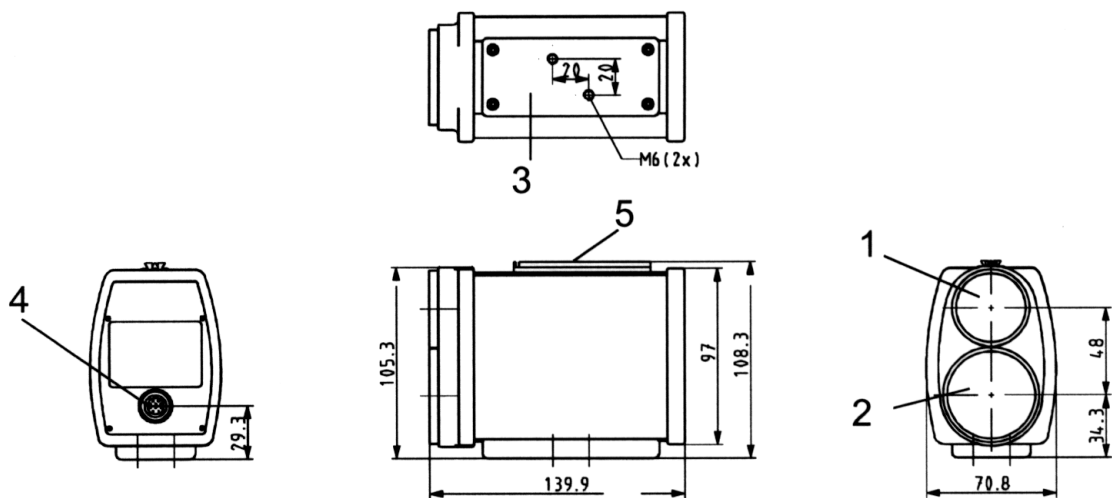

- (1) Transmitter optics
- (2) Receiver optics
- (3) Base plate for mechanical attachment
- (4) Connector port for interface cable (external power supply, RS232/RS422 interface, switching output, analog output)
- (5) Notch and bead sight, holder for light point sight

6. Connection to Cable Port

The interface cable must be connected to the cable port in accordance with the pin and jack assignment table provided below

View of back wall of LS 1500F module

- o Pin contact
- 0 Jack contact

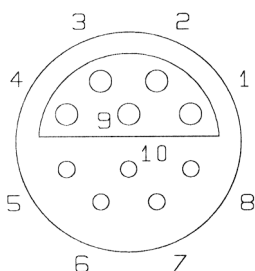

1	black
2	Brown
3	Red
4	Orange
5	Yellow
6	Green
7	Blue
8	Purple
9	Grey
10	white

Pin No.	Designation	Function with RS232	Function with RS422	Type
1	ALARM	Digital switching output	Digital switching output	Jack
2	TxD / RX+	RS232 transmission data	RS422 reception data +	Jack
3	RxD / RX-	RS232 reception data	RS422 reception data -	Jack
4	GND	Ground potential	Ground potential	Jack
5	TRIG	External synchronisation	External synchronisation	Pin
6	VCC	Supply voltage	Supply voltage	Pin
7	MODE	Operating mode	Operating mode	Pin
8	IOUT	Current output	Current output	Pin
9	TX-		RS422 transmission data -	Jack
10	TX+		RS422 transmission data +	Pin

All voltage values quoted hereafter are referenced to the ground potential at contact point 4.

Limiting values for input voltages:

TxD	$\pm 15V$
TX+, TX-	$0.3V_{to} + 7V$
RxD, TRIG, RX+, RX-	$\pm 25 V$

Output voltages:

TxD	$\geq \pm 5 V$	with 3 kohm load at either point
TX+ TX-	$\geq 2 V$	differential at 100 ohm load

All outputs are protected against steady-state shorts.

Interface parameters

Baud rate	9600 bit/s
Character length	8 bit
Parity	none
Stopbit length	one

ALARM output

Output voltage	\geq supply voltage - 2 V
Output current	$\leq 0,5A$

Analogue current output

Current range	4 mA..20 mA (max. 500 ohm load resistance) against GND
Accuracy	$\pm 0.15\%$
Temperature drift	< 50 ppm/ $^{\circ}C$

7. User Selections

The LS 1500 F offers a menu with comprehensive setting options. The module can, thus, be matched to the local site conditions or the particular measurement task before a job sequence is triggered.

Once voltage is supplied and the internal self-testing routine has been completed successfully, the measured values are displayed cyclically in automatic mode. Internal mis-functions of the LS 1500 F are reported via special messages with a correlated error code. Cyclic output of measured values is provided with 100 Hz averaging factor. No data transmission log is created in this case. Each measurement function with cyclic data output needs to be terminated by **ESC (1Bh)**, The rangefinder module is then ready to receive control commands as described in the list below.

Command list

Command	Function	Response
I D Cr	Identification	One line consisting of device type, copyright, software version number and serial number
T P Cr	Internal temperature	T T T Cr Lf
D J Cr	Cyclic output : strength of received signals	J J J J 1 value per measurement, repetition rate 100 Hz
D T Cr Or after turning power on	Cyclic output : single distance values	Output rate : 100 Hz / averaging factor D D D D . D D if measurement correct 9 9 9 9 . 9 9 no target or target too distant
V M Cr	Single speed and distance	S V V . V D D D D . D P P P P Cr Lf If measurement correct E C C D D D D . D P P P P Cr Lf If measurement with initial distance reading failed E C C P P P P Cr Lf If measurement impaired or system error
V T Cr	Cyclic output of speed and distance	Same as single speed Approx. Number of measurements p. sec.
A C nn Cr	Alarm center	No response if value set with parameter nn; if no parameter, set value is displayed
A H nn Cr	Alarm Hysteresis	Same as Alarm Center
R B nn Cr	Range Beginning	Same as Alarm Center
R E nn Cr	Range End	Same as Alarm Center
S A nn Cr	Set Average	Same as Alarm Center (integer number 1.....1000)
S F nn Cr	Scale factor	Same as Alarm Center

= Space (20h)
 Cr = Carriage Return (0Dh)
 Lf = Line Feed (0Ah)
 DDDD.DD = Distance value in metres, with cm resolution
 J J J J = Adjustment value (no unit of measure, range about 100 ... 6000)
 nn = Set parameters in fixed or float point notation
 PPPP = CRC data check sum according to CCITT over all preceding characters since output of Cr Lf

S = Mathematical sign: space for positive, - for negative
 TTT = Temperature value in °C, with mathematical sign
 V.VV = Speed value in m/s, negative sign designates targets moving away

E = Error sign
 CC = Error code 10 no optical reflex signal
 11 less than 50 optical reflex signals
 12 too much spread in measured values
 14 measurement was impaired

8. Adjustable Parameters

The following parameters can be selected. They are preserved after turning the LS 1500 F off and are immediately available for use in distance tracking mode when power is turned on again. A parameter of this type can only be changed by entering a new value for it.

Averaging factor: To select averaging of 1 to 1000 successive distance shots each time before the distance value is output; is factory-set to SA1

Scaling: For multiplication of distance value with a selectable factor to achieve a change in resolution or output of results in a different unit of measure

Alarm Center: Allows selection of distance switching threshold for the switching output

Alarm Hysteresis: Allows selection of switching hysteresis for switching output
 With positive hysteresis, output
 ON switches in the event of positive excession of switching threshold +hysteresis/2 and output
 OFF in the event of negative excession of switching threshold hysteresis/2,
 With negative hysteresis, output
 OFF switches in the event of positive excession of switching threshold +hysteresis/2 and output
 ON in the event of negative excession of switching threshold - hysteresis/2,

Range Beginning: Lower distance limit of selectable distance interval

Range End: Upper distance limit of selectable distance interval

9. Starting Up

To get ready for measuring in a selected field position, train the LS 1500 F on the object to be measured (keep adjusted position stable while measurement is going on). In stationary mode, the positions of rangefinder and moving target are known. In this case, the direction of measurement must be identical with that of target motion.

With mobile or hand-held measurement, the time for which the laser beam dwells on the target must at least be as long as the time which the laser distance module takes to perform measurement.

Speed measurement requires a measuring time of 0,5 s. The time for distance measurement can be selected.

Coarse alignment of the measuring beam for a clearly visible target at up to 150 m distance can easily be achieved with the notch-and-bead sighting device.

Operating voltage is supplied at the corresponding connection points of the interface cable. A special protection logic is provided to prevent destruction of the electronic components as a result of unwanted pole reversal. The rangefinder comes factory-set to an averaging factor of SA1. Distance measurement readings are displayed at 100 Hz intervals immediately after operating voltage is supplied.

The measured values can be displayed with the help of a suitable PC terminal program.

Use the command DJCr for precisely aiming at a selected target. The output values indicate the strength of the return signals. Change the rangefinder's alignment slightly, until a maximum in value is obtained,

Alignment for targets at a range above 150 m should preferentially be done using the optional light point sight.

To perform mutual alignment of light point sight and measuring beam, the LS 1500 F should be trained on a small strongly reflecting solitary target, and the alignment should be optimized by determining the point of maximum signal strength. To change to distance output mode, press ESC and trigger command DTCr, or turn power off and on again.

10. Distance Measurement

By selecting an averaging factor, a desired output rate (100/ averaging factor), measuring time(1/output rate) and statistical spread can be defined for distance measurement.

Example:

Output rate	Time to measure	Statistical spread over white screen of 0.5 m x 0.5 m located at right angles with measurement direction at a distance of 100m	Averaging factor
1 Hz	1 S	± 1 cm	SA100
10 Hz	100 ms	± 2cm	SA10
100 Hz	10 ms	± 7cm	SA1

Entering a scale factor SF allows virtually random selection of a desired scale for distance readings. The scale factor acts independently of the currently set averaging factor. You can, thus, match the resolution of measured values and the unit of measure to the particular measurement task.

Examples:

Resolution	Reading	Unit of measure	Scale factor
1 cm	234,56	m	SF1
1 mm	2345,61	dm	SF10
0.01 yard	256.52	yard	SF1.0936
0.01 feet	769,56	feet	SF3.28084
1 inch	92.35	100inch	SF0.3937

The switch output signals positive or negative excession of a pre-defined distance switching threshold with hysteresis band (Alarm Center). The switching hysteresis for distance mode is defined through selection of a switching threshold (Alarm Hysteresis).

Example: Monitoring a closed door relevant for safety consideration located at a distance of 100 m; door opens toward measuring site.

Command SA100	1 Hz distance output rate (switching mode option)
Command SF1	1cm resolution, unit of measure: m
Command AC 99.70	Distance switching threshold set at 99,70 m
Command AH 0.10	Distance hysteresis set at 10 cm

The switching output will be in ON status when a distance of 100 m has been measured. As the door opens, the output switches to "OFF" at the moment the measured distance equals 99.60 m. It remains in OFF status with any distance less than 99,60 m. When the door is subsequently closed again, the output switches back to "ON" as soon as the measured distance exceeds a value of 99.80 m.

The hysteresis value should be selected to be larger than the actual spread in measured values.

For standardized analog two-wire transfer of distance data over greater lengths, an analog output port is provided.

The current signal impressed on this transfer line is proportional to the measured distance within a distance interval that can be selected via "Range Beginning" and "Range End".

The value for output current (in mA) is determined through the following calculation formula:

$$IOUT(mA) = 4 + 16 * \frac{Dist.val. - Rnge.Begin}{Rnge.End - Rnge.Begin}$$

If, in accordance with this formula, positive excession of " Range End" causes an output current above 20 mA or negative excession of " Range Beginning" an output current below 4 mA, then limit value 20 mA or 4 mA will be reported.

11. Speed Measurement

Short measuring times (0.5 s) allow motor vehicles to be monitored even at high travel speeds.

Make sure the rangefinder is continuously aimed at the same spot on the vehicle as long as measurement lasts.

To facilitate this process, the light point sight can be mounted onto a stand for tracking the target. This helps obtain unblurred readings and reduces operator fatigue during observation and measurement.

The aiming path must be free from bushes, trees, masts, persons, etc. to assure direct visual contact with target and unobstructed passage of the measuring beam. There must be no depressions or elevations in the road section which is passed by the vehicles during speed measurement. These would require up or down tilting of the rangefinder while the respective vehicle is tracked for speed measurement. Continuous tilt motion, especially up or down variations over the vehicle's body shape or the surface of the road should be avoided during any measurement process.

The directions of measurement and vehicle motion should have a preferentially small mutual angle. Otherwise, the amount of change in vehicle distance registered in the direction of the rangefinder is smaller than the actual distance the vehicle has covered on the road.

Since the changes in distance are referenced to fixed time intervals to serve as the basis for speed calculation, the recorded speed would be lower than the actual motion speed of the vehicle if the mutual angle gets too large. This is also known as the "Cosinus effect".

The selected target distance should be at least ten times larger than the possible lateral offset of the measurement site from the direction of vehicle motion. In this case, the recorded speed is only just 0.5% lower than the actual vehicle motion speed.

Examples: With a lateral offset of 10 m, speed measurement should be over 100 m or more.

Accordingly, when there is a lateral offset of 15 m, the target distance should be equal or larger than 150 m, etc.

A single shot in speed mode can be triggered via VM command, a sequence of single shots via command VT.

One single shot consists of 50 distance readings obtained at a repetition rate of 100 Hz.

The measuring time of 0.5 s is followed by an evaluation time portion of 0,125 s. A sequence of single shots consists of single shots which are triggered at intervals of 0,625 s.

Each speed reading is displayed in units of m/s.

The minimum required limiting distance for achieving reasonable speed results is 0.5 m.

The upper limit for target distances in speed monitoring depends on the target's reflectivity, on the potential stray light influences and atmospheric conditions. For licence plates, this limit is at 600 m, for example.

Each single shot is recorded with an accuracy of 0,3 m/s.

The measured speed values are displayed together with the motion direction of the targeted vehicle. This is done via a "-" sign for approaching vehicles (preceding the speed value). In the event of away motion, the speed values are represented without mathematical sign.

No output or failure to produce distance readings within a defined time, too much spread in the measured values for evaluation by regression line, or measurement impaired by an optical jamming source or a distance sensor will produce an Ecc error message.

Error code	Type of error	Cause
E10	Failure to measure	No target recorded or Target too remote
E11	Measurement uncompleted	Target partially hidden or at limit of operating range
E12	Measurement unstable	Irregular target Contour or "blurred"
E14	Measurement impaired	Target contains laser jamming emitter or laser distance sensor

12. Operating Range

The operating range may be constricted by:

- surfaces providing poor reflection (e.g. black) or covered with very coarse structures,
- strongly shining surfaces or surfaces with an inclination angle to the measuring beam,
- strongly insolated surfaces,
- strong back lighting,
- fog, rain, snow, atmospheric dust,

Reflecting surfaces or window panes may re-direct the laser beam onto another target, thus, falsifying the recorded distance.

If the measurement beam is directed through a glass sheet, there may be mirroring effects or the beam might fall on other objects behind the glass.

Targets smaller in size than the laser measurement spot cannot be sighted reliably.

When there is blurring during the measurement time, various distances may get recorded.

These are then averaged and the mean value over all individual readings is turned out.

If, at the time of target sighting, a reflecting object happens to be near the measuring beam, but before the target, the rangefinder result may be falsified. In many cases, a sheet of white paper or cardboard can be applied for better target definition.

A plastic reflector from the optional accessories set should be used only for distances over 100m

The zero-point for LS 1500 F distance measurement is in the middle of rangefinder's base plate.

Laser measurement determines the distance from this distance zero-point to the sighted surface of a target positioned at right angles with the measuring beam.

For a comparison, some reflection coefficients are quoted for various sample materials:

Plastic reflector	2000 %
White paper	90 %
Bright walls	80 %
Bright wood	40 %
Concrete	30 %
Black paper	10 %

13. Performance Specifications

Specification:

Measurement range ^{*1} :	0.5 m to 400 m on white surface up to 200 m on earth or concrete beyond 1500 m on plastic reflector
Laser divergence ^{*2} :	3 mrad
Laser classification :	Class 1 laser as per EN 60825-1 :1997-03
Operating temperature:	-20°C to +60°C
Storage temperature:	-40°C to +70°C
Supply voltage ^{*7} :	10 V to 30 V DC
Power consumption ^{*8} :	<5W
Data interfacing ^{*7} :	RS 232 / RS 422 (switchable), Baud rate 9600, format 8n1, selection of measurement functions, scaling, measuring time via commands, output of measured values, internal temperature, error codes, external synchronisation of single shots can be provided on special request
Switching output ^{*7} :	Programmable switching threshold and hysteresis, " high-side switch", permissible load up to 0,5 A, $U_{switch} > U_{supply} - 2V$
Analog output ^{*7,9} :	Current output 4 mA to 20 mA, programmable distance range limits, load resistance $\leq 500 \Omega$
Dimensions (L x W x H):	139.9 mm x 70,8 mm x 108,3 mm
Weight:	850 g
Internal protection standards:	IP 65
Mech. mounting:	2 threaded holes M6 x 6 deep
Included in delivery:	LS 1500 F, interface cable, user manual
Optional accessories:	Reserve interface cable, light point sight, plastic reflector

Distance measurement:

Measuring accuracy ^{*3,4} :	± 5 cm from -10°C to +40°C		
	± 10 cm from -20°C to +60°C		
Resolution of measured values ^{*5} :	1 mm, randomly scaleable		
Statistical spread ^{*6} :	± 7 cm	± 2 cm	± 1 cm
with measuring time of:	10 ms	100 ms	1 s

Speed measurement:

Speed range: 0 ms⁻¹ to 70 ms⁻¹
Measuring accuracy*3: 0,3 ms⁻¹
Measuring time: 0,5 s

*1 Depends on target reflectivity, stray light influences and atmospheric conditions

*2 At a distance of 100 m, the beam diameter is 0.3 m

*3 Reflection coefficient $\rho > 20\%$

*4 Standard deviation

*5 Units of measure: m, dm, yard, feet, 100 inch; accuracy selectable to two digits after decimal point

*6 When sighting a planar white screen at 100 m distance positioned at right angles with the direction of measurement

*7 One jack port for supply voltage, RS232/RS422, switching output, analog output,

*8 Not considering switched electrical load

*9 Only for distance measurement

14. Service, Maintenance, Warranty

Warranty will be one year.

During this warranty period, the LS 1500 F can be checked for proper function if requested by the customer. This check will be carried out at no cost to the customer.

To check all product functions and allow unobstructed handling of your business commitments, we would suggest that you have the laser distance measurement module LS 1500 F inspected at our facility after 4500 operating hours or at yearly intervals.

Should a repair become necessary please pack the rangefinder carefully and send it to our address.

15. EC Conformity Declaration

According to the terms of EMC Directive 89/336/EWG, Appendix 1 the:

Laser Distance Measurement Module LS 1500 F

complies with the harmonised standards in EN55022 (class 6) and EN 50082, Part 2,